

HOOD TYPE DISHWASHERS AM SERIES



HOBART UK,
SOUTHGATE WAY,
ORTON SOUTHGATE,
PETERBOROUGH.
PE2 6GN
0844 888 7777

www.hobartuk.com

Hood Type Dishwasher With Drain Heat Recovery Unit and Inbuilt Softener

AMXRSW-10B

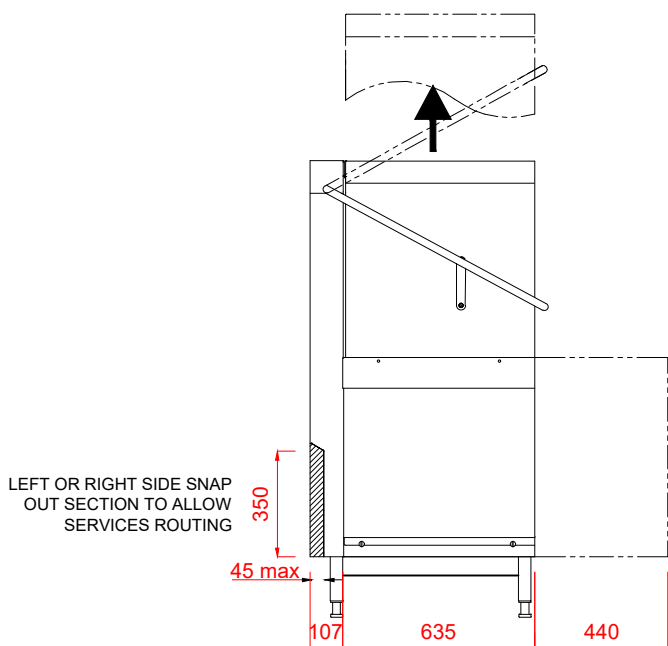
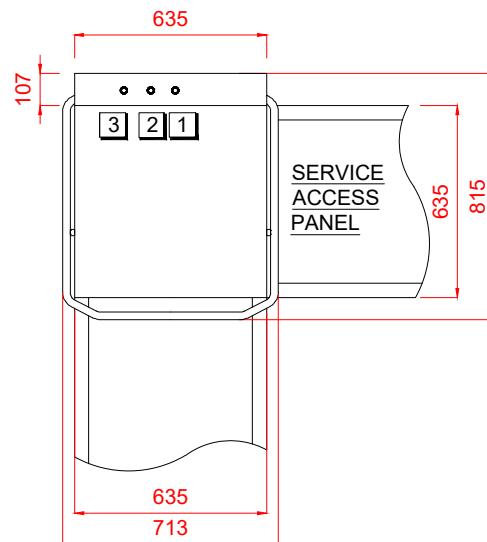

LEFT OR RIGHT SIDE SNAP
OUT SECTION TO ALLOW
SERVICES ROUTING

ESSENTIAL FOR
SERVICE ACCESS

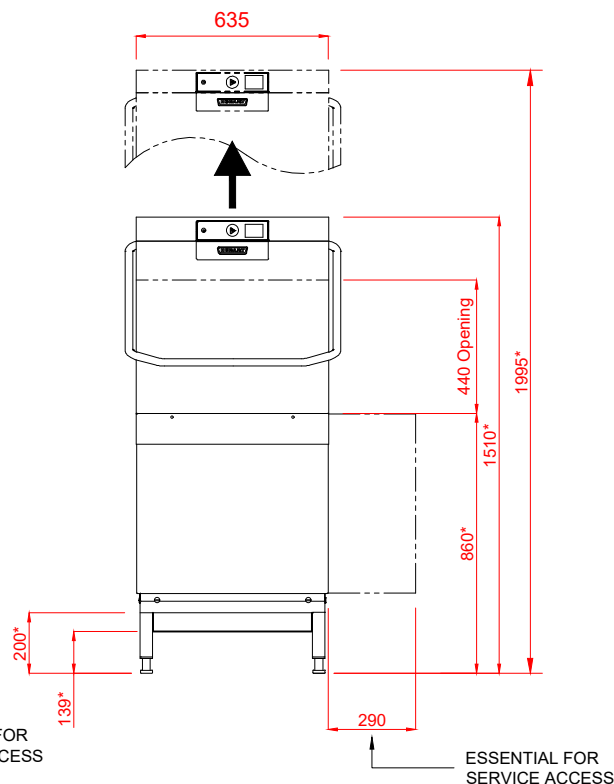

ESSENTIAL FOR
SERVICE ACCESS

1 Water

22mm CONNECTION VIA 2 METRE FLEXIBLE HOSE, FEMALE TERMINATION.

WATER SUPPLY MAX 15°C (2° TO 8° CLARK MAX) @ 0.8 TO 10.0 BAR MAX. INITIAL TANK FILL 23 LITRES.

RINSE WATER USAGE 2.0 LITRES PER CYCLE. MAX USAGE 120 LITRES PER HOUR.

OUR MACHINES ARE SUPPLIED WITH CLASS 'AB' AIR GAP AS STANDARD.

2 Drain

DRAIN - 2 METRE FLEXIBLE HOSE TO A 40 mm TRAPPED STANDPIPE 500mm MAX A.F.F.L.

FLOW RATE 30 LITRES PER MINUTE. DRAIN RATE TYPICALLY 3 MINUTES.

Other Services

RINSE AGENT HOSE - 2.5 METRE FLEXIBLE. DETERGENT HOSE - 2.5 METRE FLEXIBLE.

3 Electric

7.1kW 400/50/3 + N + E FUSED AT 16amps / PHASE. MACHINE SUPPLIED WITH 2.5 METRES OF CABLE (3 PHASE).

CONFIGURABLE TO:
5.0kW 230/50/1 FUSED AT 25amps

Notes

Approx Weights: EMPTY: 110kg WITH WATER: 130kg
Min distance to Wall to Inside of tabling boxed edge 154.5mm.
HEIGHTS MARKED * REPRESENT ±20mm.

PLOT SCALE: 1:25

RIGHT TO MAKE NECESSARY CHANGES IS RESERVED