

Twin Hood Type Pass Through Dishwasher with Automatic Soil Removal

AUPTW-10B

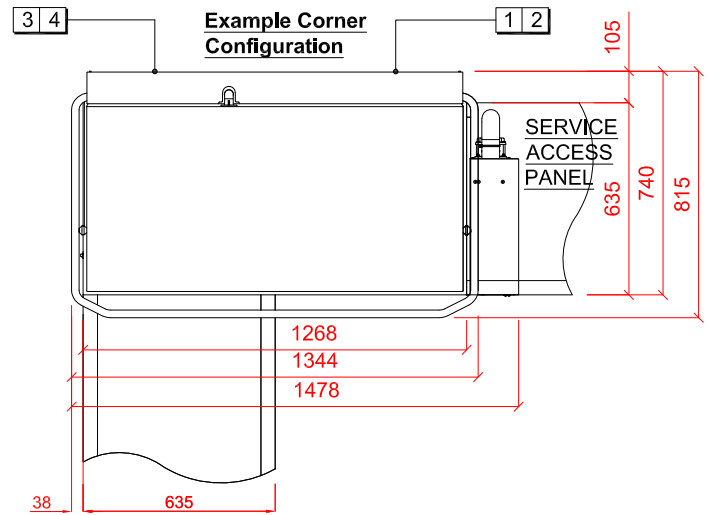
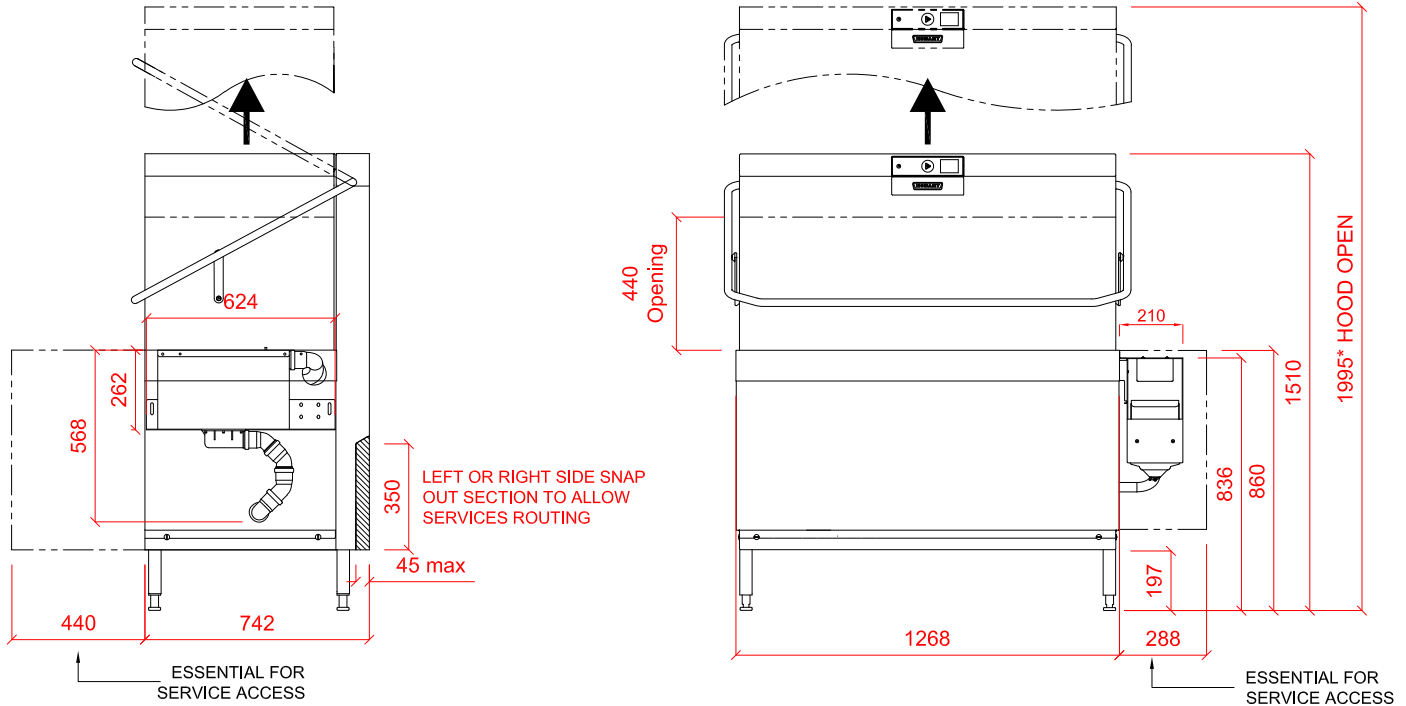

1 Water

22mm CONNECTION VIA 2 METRE FLEXIBLE HOSE, FEMALE TERMINATION. WATER SUPPLY 10°C TO 50°C (2 TO 8° CLARK) @ 0.5 TO 10 BAR MAX. FOR 12.3kW BOOSTER HEATING.  
**OR**  
WATER SUPPLY 50°C (2 TO 8° CLARK) @ 0.5 TO 10 BAR MAX. FOR 6.15kW BOOSTER HEATING. INITIAL TANK FILL 80 LITRES. RINSE WATER USAGE 4.0 LITRES PER CYCLE. MAX USAGE 280 LITRES PER HOUR. OUR MACHINES ARE SUPPLIED WITH CLASS 'AB' AIR GAP AS STANDARD.

2 Drain

DRAIN - 2 METRE FLEXIBLE HOSE TO A 40 mm TRAPPED STANDPIPE 500mm MAX A.F.F.L.  
  
FLOW RATE 30 LITRES PER MINUTE. DRAIN RATE TYPICALLY 3 MINUTES.

3 Electric

23.5kW 400/50/3 + N + E FUSED AT 40amps / PHASE. CONFIGURABLE TO: 17.3kW 400/50/3 + N + E FUSED AT 32amps/ PHASE. SUPPLIED WITH 2.5 METRES OF CABLE.

4 Other Services

RINSE AGENT HOSE - 2.5 METRE FLEXIBLE. DETERGENT HOSE - 2.5 METRE FLEXIBLE.

Notes

Approx Weights: EMPTY: 180kg WITH WATER: 212kg  
Min distance to Wall to Inside of tabling boxed edge 154.5mm.  
HEIGHTS MARKED \* REPRESENT ±20mm.  
AUTOMATIC SOIL REMOVAL UNIT CAN BE POSITIONED ON EITHER SIDE OF MACHINE.