

**FOOD PREPARATION
PEELERS**



HOBART UK,
SOUTHGATE WAY,
ORTON SOUTHGATE,
PETERBOROUGH.
PE2 6GN
0844 888 7777

www.hobartuk.com

13kg Potato Peeler with Built-in Peel Trap, Hose Connector and Legs

E6128M-10

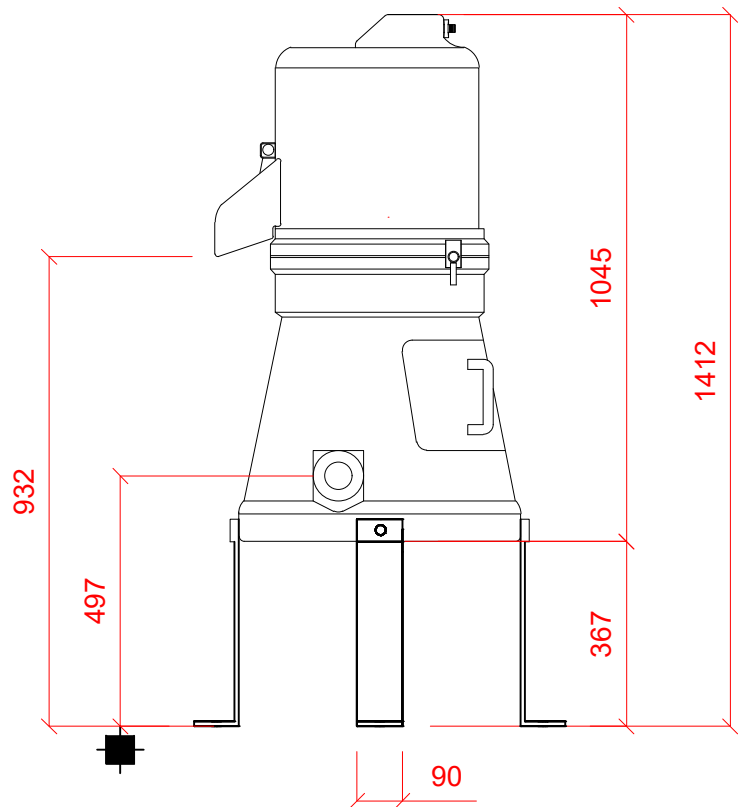
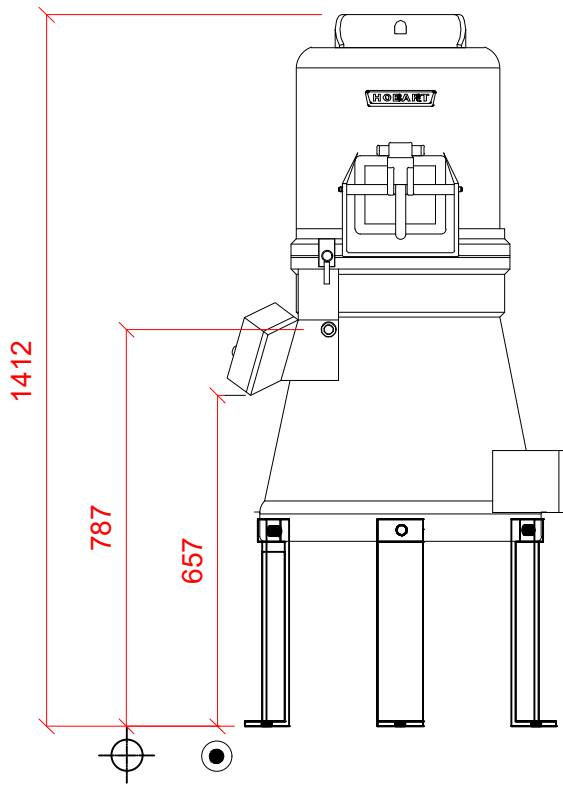
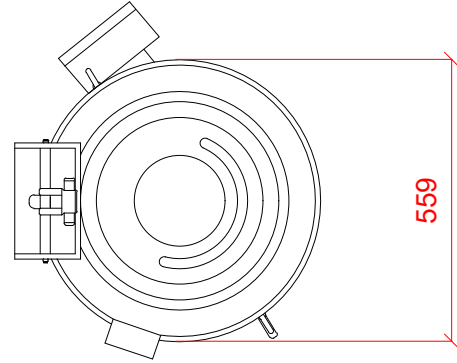

2 Water	2 Drain	3 Electric
1/2" B.S.P. POTABLE COLD WATER	50mm	0.37kW 230/50/1 FUSE AT 15 AMPS

NOTE: HOLES NEED TO BE DRILLED INTO FLOOR SO LEGS CAN BE BOLTED SECURELY.

PLOT SCALE: 1:15

RIGHT TO MAKE NECESSARY CHANGES IS RESERVED