

Twin Front Loading Utensil Washer

UPT-10B

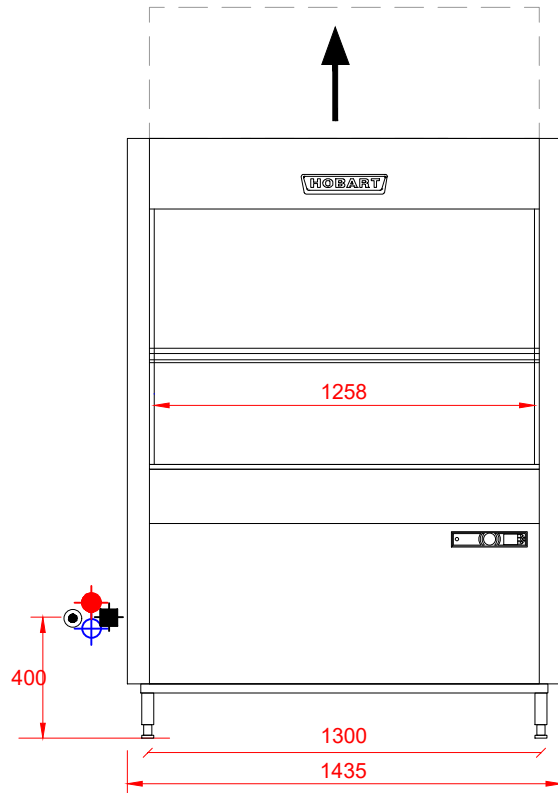
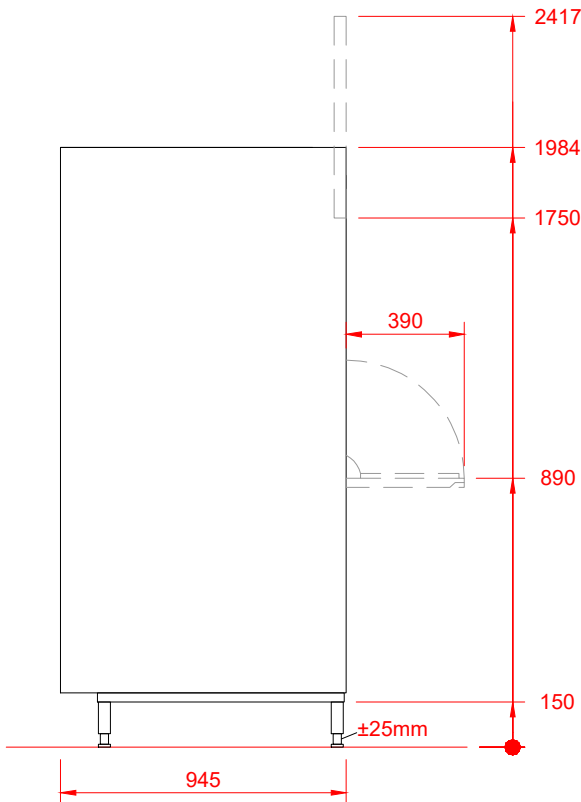
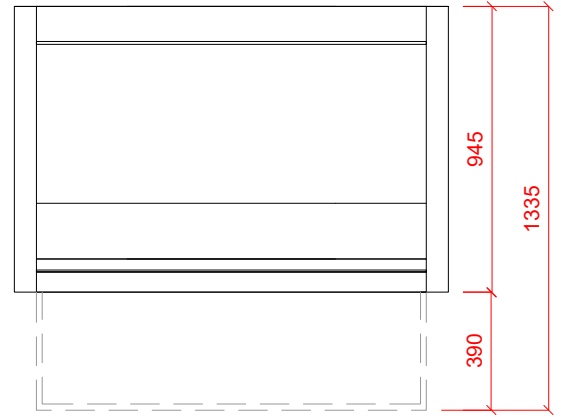

**1 Water**

2 x 22mm CONNECTIONS EACH VIA 1.5 METRE FLEXIBLE HOSE, FEMALE TERMINATION.  
1 x WATER SUPPLY UP TO 65°C @ 0.5 TO 10 BAR MAX. INITIAL TANK FILL 130 LITRES.

1 x WATER SUPPLY UP TO 15°C RINSE WATER USAGE 14.0 LITRES PER CYCLE MAX USAGE 420 LITRES PER HOUR.

OUR MACHINES ARE SUPPLIED WITH CLASS 'AB' AIR GAP AS STANDARD. WATER SUPPLY TO HAVE INDEPENDENT ISOLATING VALVE.

**2 Drain**

DRAIN - 2 METRE FLEXIBLE HOSE TO A 40 mm TRAPPED STANDPIPE 800mm A.F.F.L.

FLOW RATE 30 LITRES PER MINUTE.

**Other Services**

RINSE AGENT HOSE - 2.5 METRE FLEXIBLE.  
2 x DETERGENT HOSES - 2.5 METRE FLEXIBLE.

**3 Electric**

23.5kW 400/50/3 + N + E FUSED AT 3 X 50AMPS.  
Configurable to:  
18.3kW 400/50/3 fused at 3x32amps,  
29.5kW 400/50/3 fuse at 3x50amps

MACHINE SUPPLIED WITH 1.8 METERS OF CABLE.

**Notes**

APPROX WEIGHTS: EMPTY: 305kg's

HEIGHTS MARKED \* REPRESENT ±25mm