

Twin Pass Through Utensil Washer

UXTLH-10B

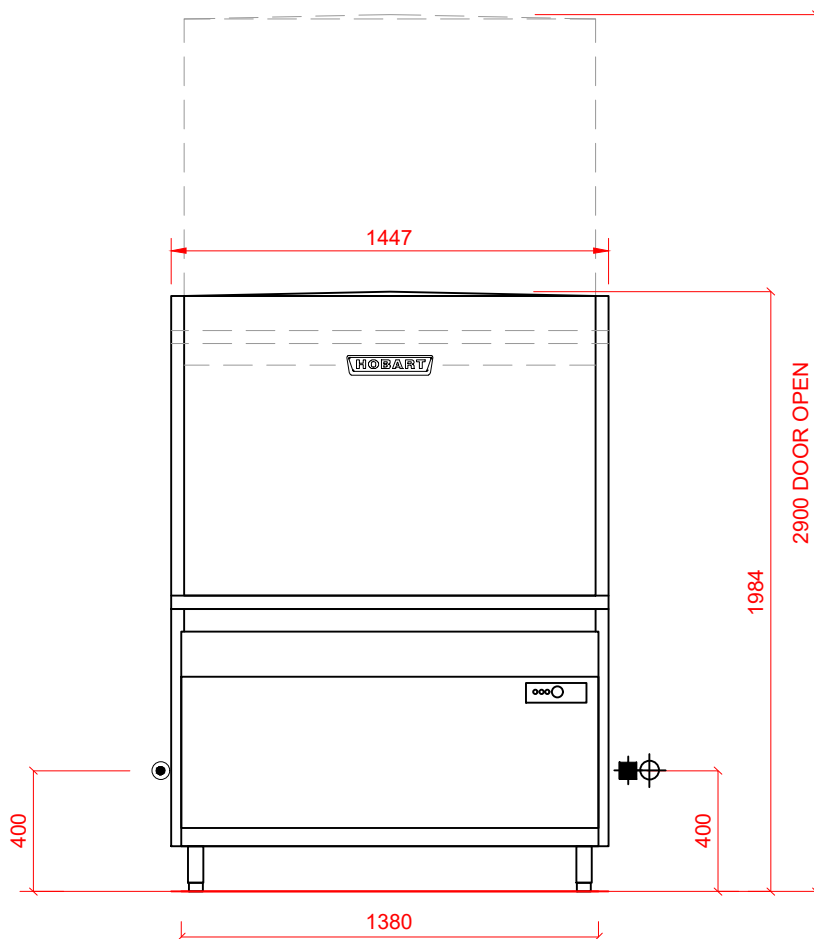
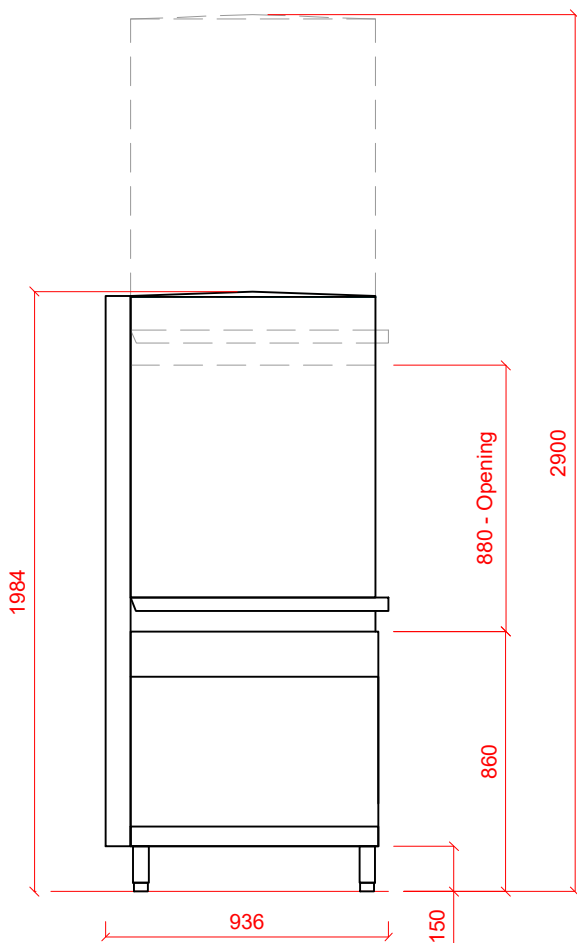
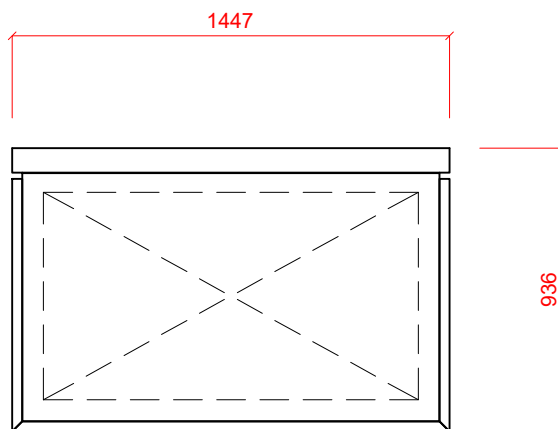

**1** Water

22mm CONNECTION VIA 1.5 METRE FLEXIBLE HOSE, FEMALE TERMINATION.

WATER SUPPLY 15°C TO 60°C (2° TO 8° CLARK MAX) @ 0.5 TO 10 BAR MAX.  
INITIAL TANK FILL 130 LITRES.  
RINSE WATER USAGE 6.9 LITRES PER RACK CYCLE.  
MAX USAGE 207 LITRES PER HOUR.  
OUR MACHINES ARE SUPPLIED WITH CLASS 'AB' AIR GAP AS STANDARD. WATER SUPPLY TO HAVE INDEPENDENT ISOLATING VALVE.

**2** Drain

DRAIN - 2 METRE FLEXIBLE HOSE TO A 40 mm TRAPPED STANDPIPE 800mm A.F.F.L.

FLOW RATE 30 LITRES PER MINUTE.

**3** Electric

20.6kW 400/50/3 + N + E FUSED AT 35amps  
CONFIGURABLE TO:  
15.5kW 400/50/3 + N + E FUSED AT 25amps  
26.6kW 400/50/3 + N + E FUSED AT 50amps

MACHINE SUPPLIED WITH 1.8 METRES OF CABLE.

Other Services

Notes

APPROX WEIGHTS: EMPTY: 364kg's  
HEIGHTS MARKED \* REPRESENT ±25mm  
OPERATING HEIGHT FOR TABLE: 860mm