

Twin Pass Through Utensil Washer with Drain Heat Recovery

UXTLHR-10B

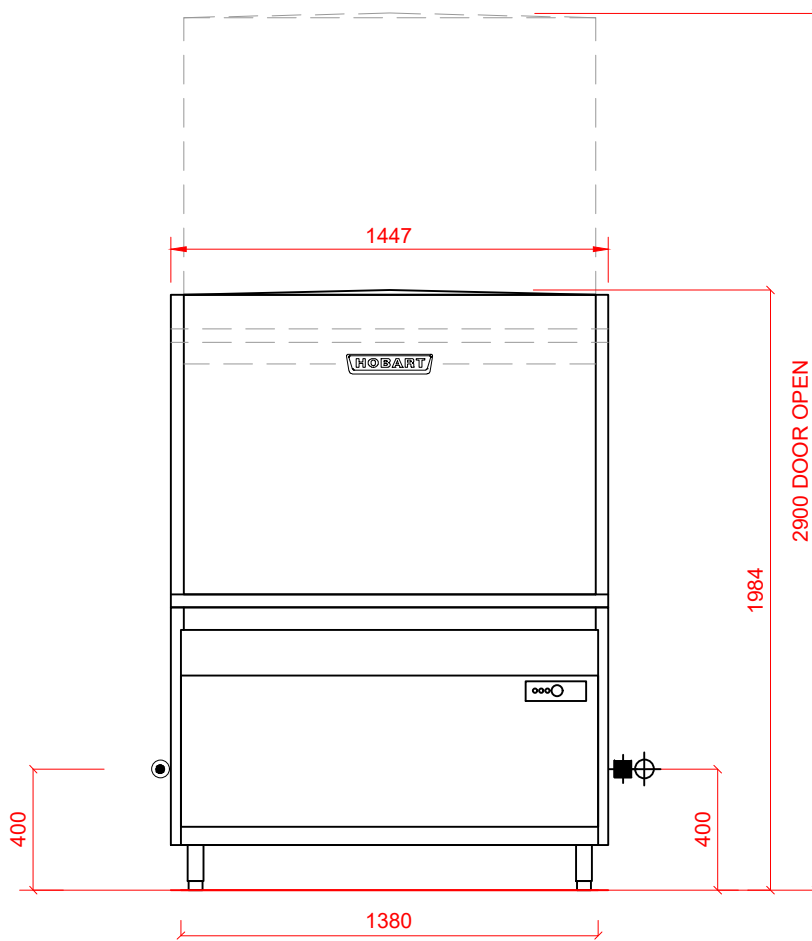
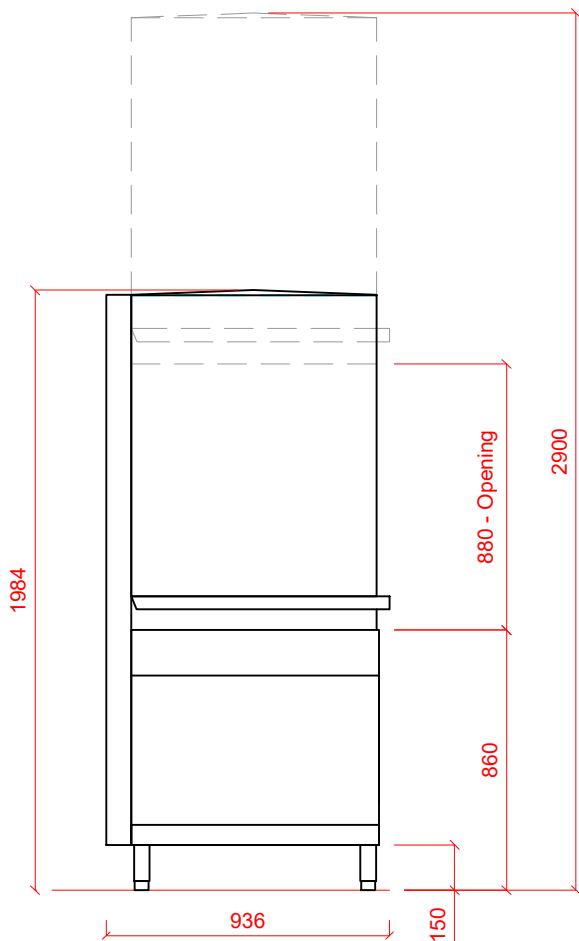
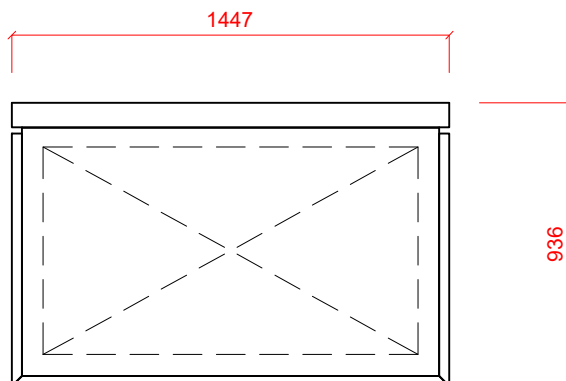

1 Water	2 Drain	3 Electric
<p>22mm CONNECTION VIA 1.5 METRE FLEXIBLE HOSE, FEMALE TERMINATION.</p> <p>WATER SUPPLY 15°C TO 60°C (2° TO 8° CLARK MAX) @ 0.5 TO 10 BAR MAX.</p> <p>INITIAL TANK FILL 130 LITRES.</p> <p>RINSE WATER USAGE 6.9 LITRES PER RACK CYCLE. MAX USAGE 207 LITRES PER HOUR.</p> <p>OUR MACHINES ARE SUPPLIED WITH CLASS 'AB' AIR GAP AS STANDARD. WATER SUPPLY TO HAVE INDEPENDENT ISOLATING VALVE.</p>	<p>DRAIN - 2 METRE FLEXIBLE HOSE TO A 40 mm TRAPPED STANDPIPE 800mm A.F.F.L.</p> <p>FLOW RATE 30 LITRES PER MINUTE.</p>	<p>20.6kW 400/50/3 + N + E FUSED AT 35amps CONFIGURABLE TO: 15.5kW 400/50/3 + N + E FUSED AT 25amps 26.6kW 400/50/3 + N + E FUSED AT 50amps</p> <p>MACHINE SUPPLIED WITH 1.8 METRES OF CABLE.</p>
	Other Services	Notes
	<p>RINSE AGENT HOSE - 2.5 METRE FLEXIBLE</p> <p>DETERGENT HOSE - 2.5 METRE FLEXIBLE</p>	<p>APPROX WEIGHTS: EMPTY: 415kg's</p> <p>HEIGHTS MARKED * REPRESENT ±25mm</p> <p>OPERATING HEIGHT FOR TABLE: 860mm</p>